



## Products and Solutions

To Measure, Monitor and Control



Flow

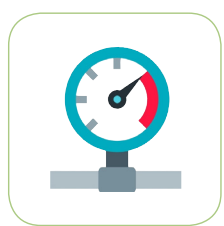

Pressure

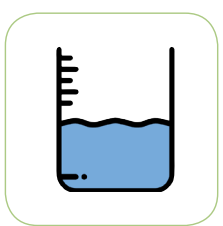

Level



Temperature



Analytical

For The Process Industries

## Specification

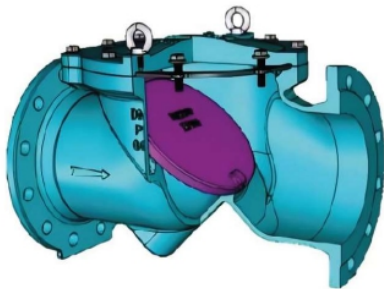
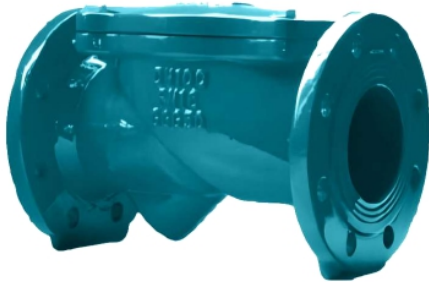

45° closing angle - minimize closure time

35° max open- enough flow area

Disc: Ductile iron+EPDM

The cover is removable and allow removal of the disc without removing the valve from the pipeline.

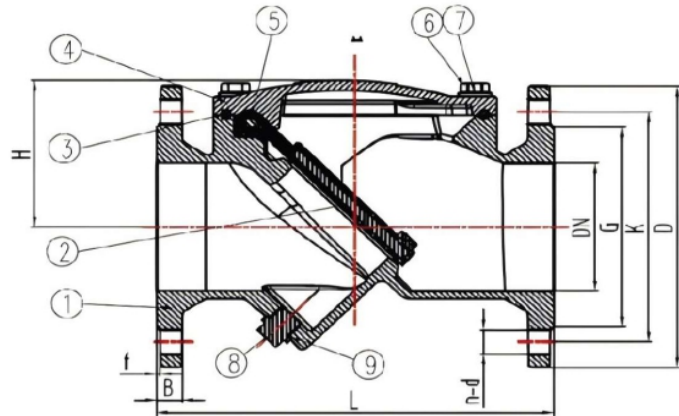

ITEM	PART NAME	MATERIAL
1	Body	Ductile iron
2	Disc	Ductile iron + EPDM
3	Gasket	NBR
4	Bonnet	Ductile iron
5	Pin	SS420
6	Bolt	SS304
7	Washer	SS304
8	Plug	SS304
9	O-Ring	NBR

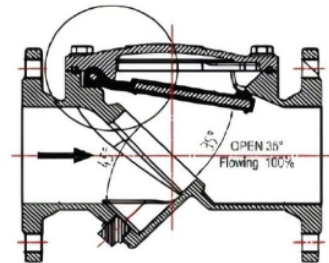
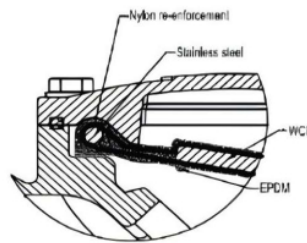

Size	Face to face dimension(mm)		Flange dimension(EN 1092-2,BS4504)PN10/PN16						
	DN	BS 5153 BS EN12334	D	K	G	n-d	B	f	H
DN50/2"		203	165	125	99	4-Φ19	19	3	88
DN65/2.5"		216	185	145	118	4-Φ19	19	3	100
DN80/3"		241	200	160	132	8-Φ19	19	3	108
DN100/4"		292	220	180	156	8-Φ19	19	3	118
DN125/5"		330	250	210	184	8-Φ19	19	3	150
DN150/6"		356	285	240	211	8-Φ23	19	3	160
DN200/8"		495	340/340	295/295	266	8-Φ23/12-Φ23	20	3	250
DN250/10"		622	395/405	350/355	319	12-Φ23/12-Φ28	22	3	295
DN300/12"		698	445/460	400/410	370	12-Φ23/12-Φ28	24.5	4	330



**AE** ANDERSON  
EUROTECH  
VALVES AND INSTRUMENTS

For Your Sales and After Sales, please contact:

Indonesia Sole Distributor

**PT. Multi Sukses Pratama**

Jl. Bandengan Utara No. 80  
Rukan Bandengan Indah D No.20

Jakarta Utara, Indonesia

☎ (62) (21) 29379590, 29379591, 68292838, 8822918 (62)

☎ (21) 29379571

E-mail: [sales@suksespratama.com](mailto:sales@suksespratama.com)