



## Products and Solutions

To Measure, Monitor and Control



Flow

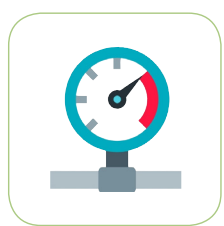

Pressure

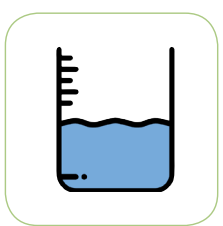

Level



Temperature



Analytical

For The Process Industries

# AE219 Solenoid Valve (With Namur Interface)



## Design

The AE219 solenoid valve is an air spring return 3/2 way or 5/2 way valve and is used for the pneumatic control of double or single-acting actuators. It is available in Namur 1-G1/4", or Namur 2-G1/2" connection and interface with manual override as a standard feature.

## Features and Benefits

- Air re-circulation for 3/2 way valve - prevents external moist or corrosive air into spring chamber of actuator
- High quality anodized aluminum body with stainless steel spool and brass inner part with special sealing system for high reliability without stick slip effect
- Coil nut with sealing and O ring seal between coil and valve head offers excellent protection of coil in wet and humid environment
- Fully encapsulated thermoplastic coil, 360° rotatable for easy electrical wiring

## Specifications

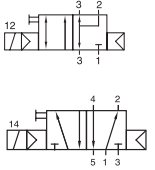
Function	 <p>3/2 way normally closed with air re-circulation (normally open on request)</p> <p>5/2 way</p>
Air Flow	1250 l/min (Namur 1) *3000 l/min (Namur 2)
Operating Pressure	2 - 10 bar
Media and Ambient Temperature	-10°C to +60°C (with DC coil) -10°C to +50°C (with AC coil) *Higher temperature version up to +80°C version *Lower temperature version down to -40°C
Media	Clean lubricated or unlubricated compressed air with air quality in accordance to ISO 8573-1:2010, Class 7.4.4
Coil Voltage	24VDC *24V 50/60Hz *110V 50/60Hz 230V 50/60Hz
Voltage Tolerance	±10%
Power Consumption	5VA~ / 3W=
Response Time	50 msec
Duty Cycle	100% ED
Leakage Rate Tolerance @ 6 bar pressure	Internal: 4 cm <sup>3</sup> /min External: 2 cm <sup>3</sup> /min

Orifice	7 mm (Namur 1) *12 mm (Namur 2)
Inlet and Exhaust Port	G1/4" (Namur 1) *G1/2" (Namur 2) *NPT1/4" (Namur 1) *NPT1/2" (Namur 2)
Outlet Port	Namur 1 Interface (G1/4") *Namur 2 Interface (G1/2")
Installation	Directly mounted to pneumatic actuator with Namur interface
Enclosure Protection	IP65 with correct installation of cable plug *IP67
Materials	
Body	Anodised Aluminum *1.4404 Stainless Steel
Spool	1.4104 Stainless Steel
Core Tube	Brass *Stainless Steel
Sealing System	Brass and NBR
Other Inner Parts	Brass, POM, NBR
Pilot Valve Base	Fibre-enforced PA *Aluminum
Manual Override	Brass *Stainless steel, with combination of Aluminum pilot valve base
End Cap	Brass *Stainless Steel

\* Options available on request

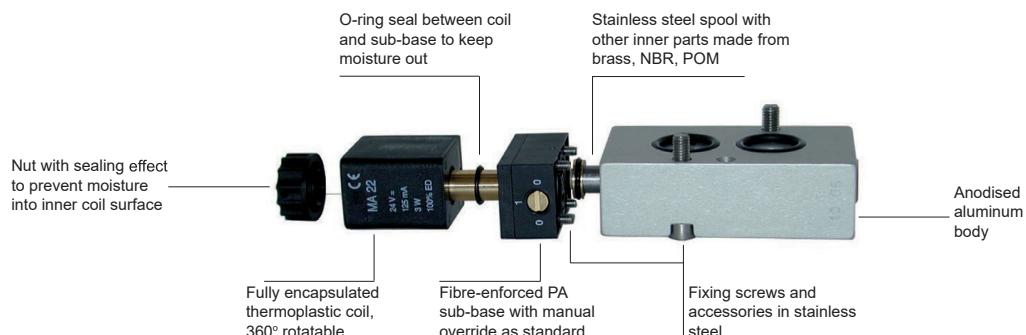

The specifications given in this document represent the state of engineering at the time of publishing. We reserve the right to make modifications to the specifications and materials.

# AE219 Solenoid Valve (With Namur Interface)

## Dimensions (mm) (Namur 1-G1/4")

3/2 Way

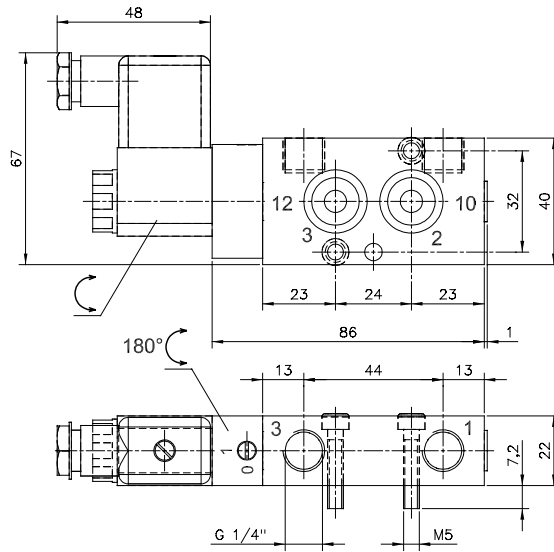
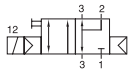

5/2 Way

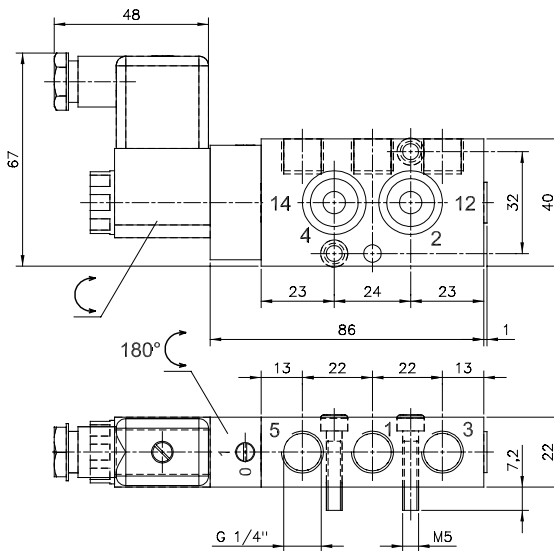
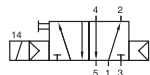

## Some Other AE219 Namur Versions



Double Coils Version



Air Pilot Version



Lever Operated Version



Version with Manual Reset Function



Version with Latch Lock Function



Version with Electrical Feedback



Version with Ex m Coil



Version with Ex ia Coil



Version with Ex d Coil



Control Block for butterfly valve with inflatable valve seat



**AE** ANDERSON  
EUROTECH  
VALVES AND INSTRUMENTS

For Your Sales and After Sales, please contact:

Indonesia Sole Distributor

**PT. Multi Sukses Pratama**

Jl. Bandengan Utara No. 80  
Rukan Bandengan Indah D No.20

Jakarta Utara, Indonesia

☎ (62) (21) 29379590, 29379591, 68292838, 8822918 (62)

☎ (21) 29379571

E-mail: [sales@suksespratama.com](mailto:sales@suksespratama.com)