



## Products and Solutions

To Measure, Monitor and Control



Flow



Pressure

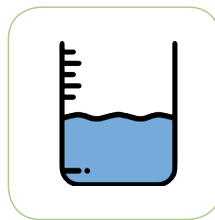

Level



Temperature



Analytical

For The Process Industries

# AE PRESSURE REDUCING VALVE

This series reducing valve is pilot piston type reducing valve for steam, mainly composed of main valve and pilot valve. The main valve consists of valve seat, main valve disc, piston, cylinder sleeve, and spring. The piston valve consists of valve seat, valve flap, membrane, spring and adjusting spring. Set the outlet pressure through adjusting spring, sense the change of pressure of outlet with membrane, adjust the flow area of throttling part of main valve through open and close of pilot valve and drive the piston, to realize the function of reducing and regulating valve. The product is mainly applied on steam piping, to reduce and regulate the pressure.

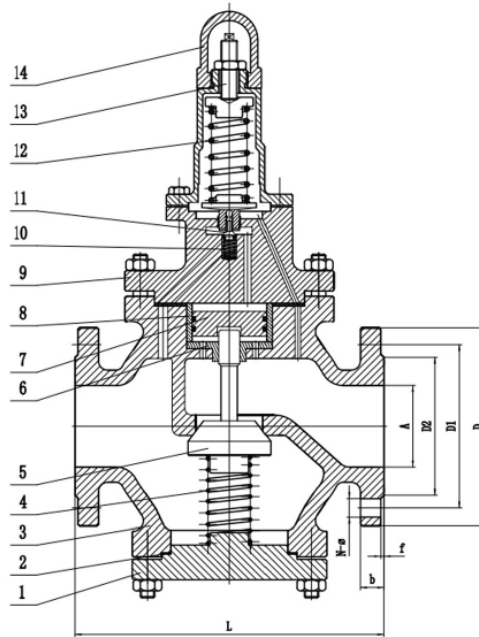

NO	Name	Material
1	Bottom cover	WCB
2	Gasket	SS+graphite
3	Bonnet	WCB
4	Spring	65Mu
5	Disc	2Cr13
6	Guide sleeve	304
7	piston	QT450
8	bushing	304
9	Bonnet	WCB
10	Spring	304
11	Disc	2Cr13
12	Spring	65Mu
13	Screw	CS
14	Shield	Assembly

Performance specification			
Class		10K	
test	housing	3.0	MPa
	seal up	2.0	
	Airtight seal	0.6	
temperature	300		°C
medium	Gas or steam		
Outlet Pressure	0.25 to 0.8 MPa		

A	L	D	D1	D2	b	f	z-Φd
1"	180	125	90	70	14	1	4-Φ19
1.5"	220	140	105	85	16	2	8-Φ19
2"	250	155	120	100	16	2	8-Φ19



**AE** ANDERSON  
EUROTECH  
VALVES AND INSTRUMENTS

For Your Sales and After Sales, please contact:

Indonesia Sole Distributor

**PT. Multi Sukses Pratama**

Jl. Bandengan Utara No. 80  
Rukan Bandengan Indah D No.20

Jakarta Utara, Indonesia

☎ (62) (21) 29379590, 29379591, 68292838, 8822918 (62)

☎ (21) 29379571

E-mail: [sales@suksespratama.com](mailto:sales@suksespratama.com)