



Products and Solutions

To Measure, Monitor and Control



Flow

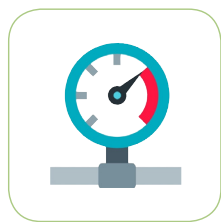

Pressure

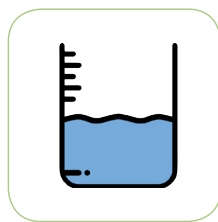

Level



Temperature



Analytical

For The Process Industries

pH electrodes/ORP electrodes

AE pH electrode is a high-quality sensor for the analysis and measurement of liquid components during industrial automation. These electrodes are known for their use of top-quality materials and components. They are designed as combined electrodes (the measuring electrode and the reference electrode are combined in one shaft). The temperature probe can also be integrated as an option.

Applications

- Wastewater
- Wet Wells
- Oil tanks
- Sumps
- Reservoirs
- Industrial wastewater
- Electroplating plants
- Paper industry
- Drinking water



Features

- Adopt international advanced solid dielectric and large area PTFE liquid junction, easy maintenance.
- Long distance reference diffusion path, extends electrode life greatly in harsh environments.
- Electrode is made of high quality low-noise cable, make signal output length greater than 40 meters or more, without interference.
- High accuracy, fast response, good repeat-ability.
- With silver ions Ag / Ag-Cl reference electrode.
- Side or vertically installation to the reaction tank or pipe.
- Electrode can be used interchangeably with similar electrodes.

AE pH SENSOR SERIES

Electrode model	Designation	pH and ORP range	Temperature range
AE-pH5011	Plastic pH electrode	2-14pH	0-60°C
AE-pH5013A	PTFE pH electrode	0-14pH	0-60°C
AE-pH5014	Glass pH electrode	0-14pH	0-130°C
AE-pH5015	High Temperature Glass	0-14pH	0-130°C
AE-pH5016	pH electrode	0-14pH	0-80/>100°C
AE-pH5017	Plastic pH electrode	0-14pH	0-130°C
AE-pH5018	Glass pH electrode	0-14pH	0-100°C
AE-pH5019	Glass pH electrode	0-14pH	0-80°C for general cables
AE-pH5022	Glass pH electrode	0-14pH	0-130°C
AE-pH6001	Plastic pH electrode	2-12pH	0-80°C
AE-pH6002	Glass pH electrode	0-14pH	0-100°C
AE-pH7001	Desulfurization electrode	0-14pH	5-80°C
AE-pH7002	Plastic pH electrode	0-14pH	5-80°C
AE-pH7003	Plastic pH electrode	2-12pH	5-80°C
AE-ORP6041	Glass ORP electrode	-2000mV-2000mV	0-80°C
AE-ORP6050	Plastic ORP electrode	-2000mV-2000mV	0-60°C

AE pH SENSOR SERIES



AE-pH5011

■ Technical parameters

Temperature compensation: Pt100/Pt1000/NTC10K
Zero potential point: 7 ± 0.25
Conversion coefficient: $\geq 95\%$
Membrane resistance: $< 500\Omega$
Practical response time: < 1 min
Reference: Ag/AgCl
Pressure resistance: 4 bar at 25 °C
Thread Connection: 3/4NPT
Material: PPS/PC

■ Application

Suitable for general industrial waste water and discharge solutions



AE-pH5013A

■ Technical parameters

Temperature compensation: Pt100/Pt1000/NTC10K
Zero potential point: 7 ± 0.25
Conversion coefficient: $\geq 95\%$
Membrane resistance: $< 500\Omega$
Practical response time: < 1 min
Salt bridge: Cyclic tetrafluoro salt bridge
Reference: Ag/AgCl
Pressure resistance: 0.3MPa
Thread Connection: 3/4NPT
Material: PTFE

■ Application

Low-impedance glass sensitive film, wear-resistant, strong acid and alkali resistant, with protection ring in the front to protect glass bulb and better precision and linearity.

AE pH SENSOR SERIES



AE-pH5014

▪ Technical parameters

Temperature compensation: Pt100/Pt1000/NTC10K
HF acid concentration range: ≤ 4000 ppm
Electrode interface: S8, VP, K2, etc.
Zero potential point: 7 ± 0.5 pH
Conversion coefficient: $> 98\%$
Membrane resistance: $< 50, 250M\Omega$
Practical response time: < 1 min
Salt bridge: Ceramic salt bridge
Pressure resistance: 0.25MPa
Thread Connection: PG13.5
Reference: Ag/AgCl

▪ Application

In the dilution control of hydrofluoric acid in semiconductor wafer fabrication and chip production; determination of pH value in petrochemical industry, iron and steel production wastewater and other strong corrosive systems.



AE-pH5015

▪ Technical parameters

Temperature compensation: Pt100/Pt1000/NTC10K
Connector: VP, S8M, K2, etc.
Zero potential point: 7 ± 0.5 pH
Conversion coefficient: $> 98\%$
Membrane resistance: general: $< 250M\Omega$
Practical response time: < 1 min
Salt bridge: Ceramic salt bridge
Pressure resistance: 0.25MPa
Thread Connection: PG13.5
Reference: Ag/AgCl
Material: Glass

▪ Application

In various chemical processes including microbial technology, pharmaceuticals, food and beverages, sugar manufacturing, chlor-alkali, mining and smelting, paper pulp, textiles, petrochemical industry and semiconductor electronic industry as well as fields such as wastewater treatment.

AE pH SENSOR SERIES



AE-pH5016

▪ Technical parameters

Temperature compensation: Pt100/Pt1000/NTC10K
Zero potential point: 7 ± 0.5 pH
Conversion coefficient: $> 98\%$
Membrane resistance: $< 250\text{M}\Omega$
Practical response time: < 1 min
Salt bridge: salt bridge porous Teflon
Pressure resistance: $1 \sim 6$ Bar at 25°C
Thread Connection: 3/4NPT

▪ Application

In wastewater treatment and in the fields including mining and smelting, papermaking, paper pulp, textiles, petrochemical industry, process of semiconductor electronic industry, and downstream engineering of biotechnology.



AE-pH5017

▪ Technical parameters

Temperature compensation: Pt100/Pt1000/NTC10K
Connector: VP, S8M, K2, etc.
Zero potential point: 7 ± 0.25 pH
Conversion coefficient: $> 98\%$
Membrane resistance: $< 600\text{M}\Omega$
Practical response time: < 1 min
Pressure resistance: up to 6 Bar at 25°C
Thread Connection: PG13.5

▪ Application

In various chemical processes including chlor-alkali, mining and smelting, papermaking, paper pulp, textiles, petrochemical industry and semiconductor electronic industry as well as fields such as biotechnology and wastewater treatment.

AE pH SENSOR SERIES



AE-pH5018

■ Technical parameters

Temperature compensation: Pt100/Pt1000/NTC10K

Pressure resistance: 0.25MPa

Connector: VP, S8M, K2, etc.

Zero potential point: 7 ± 0.5 pH

Conversion coefficient: > 98%

Membrane resistance: general: <250M Ω

Practical response time: < 1 min

Salt bridge: Porous ceramic core/ porous Teflon

Thread Connection: PG13.5

■ Application

In various chemical processes including microbial technology, pharmaceuticals, food and beverages, sugar manufacturing, chlor-alkali, mining and smelting, papermaking, paper pulp, textiles, petrochemical industry and semiconductor electronic industry as well as fields such as sewage treatment



AE-pH5019

■ Technical parameters

Temperature compensation: 10

K Ω /2.252K Ω /Pt100/Pt1000

Zero potential point: 7 ± 0.5 pH

Conversion coefficient: > 98%

Membrane resistance: <250M Ω

Practical response time: < 1 min

Salt bridge: Ceramic salt bridge

Pressure resistance: 0.1 MPa~0.3 MPa at 25 °C

Thread Connection: 3/4NPT

Material:Nylon 66 mixed glass fiber

■ Application

In sewage treatment and fields including mining and smelting, papermaking, paper pulp, textiles, petrochemical industry, process of semiconductor electronic industry and downstream engineering of biotechnology.

AE pH SENSOR SERIES



AE-pH5022

▪ Technical parameters

Zero potential point: 7 ± 0.5 pH
Conversion coefficient: > 96%
Installation size: PG13.5
Pressure: 1 ~ 6 Bar at 25 °C
Temperature: 0 ~ 130°C for general cables
Thread Connection: K8S

▪ Application

Industrial wastewater engineering including process measurements, electroplating plants, paper and drinks industry, wastewater containing oil.
Suitable for suspensions, varnishes, media containing solid particles and media containing fluorides (hydrofluoric acid) up to 1000 mg/l HF.



AE-pH6001

▪ Technical parameters

Temperature compensation: Pt100/Pt1000/NTC10K
Pressure resistance: 0.4MPa
Reference: Ag/AgCl
Thread Connection: 3/4NPT
Salt bridge: Cyclic tetrafluoro salt bridge
Material: ABS

▪ Application

In various chemical processes including water treatment, waste gas treatment, aquaculture and dosing equipment supporting.

AE pH SENSOR SERIES



AE-pH6002

■ Technical parameters

Measurement range:(0~14) pH
Temperature range:(0~100)°C
Pressure resistance:0.6MPa
Zero potential point: $E_o=7\text{pH}$
Electrode size: $\phi 12 \times 120$, 225 or other sizes
Thread: PG13.5, international standard
Electrode outer tube material: glass
Wire: 5 meters (standard), optional
Temperature compensation resistance: Pt100, Pt1000, 2.252K, 10K, 22K, etc

■ Application

In various chemical processes including microbial technology, pharmaceuticals, food and beverages, sugar manufacturing, chlor-alkali, mining and smelting, papermaking, paper pulp, textiles, petrochemical industry and semiconductor electronic industry as well as fields such as sewage treatment



AE-pH7001

■ Technical parameters

Temperature compensation: Pt100/Pt1000/NTC10K
Pressure resistance: 0.4MPa
Reference: Ag/AgCl
Thread Connection: 3/4NPT
Salt bridge: Ceramic salt bridge
Material:PPS

■ Application

In various chemical processes including high suspended solids solution, lime pool and mining.

AE pH SENSOR SERIES



AE-pH7002

■ Technical parameters

Temperature compensation: Pt100/Pt1000/NTC10K

Pressure resistance: 0.4MPa

Reference: Ag/AgCl

Thread Connection: 3/4NPT

Salt bridge: Cyclic tetrafluoro salt bridge

Material: PPS

■ Application

In various industrial processes including sewage and waste gas treatment and fields.



AE-pH7003

■ Technical parameters

Measuring range: (2~12)pH

Temperature range: (5~80)°C

Pressure resistance: 0.6MPa

Temperature compensation type: NTC10K, PT100, PT1000

Reference type: Ag/AgCl

Salt bridge: Cyclic tetrafluorosalt bridge

Mounting thread: 3/4NPT

Shell material: PPS

■ Application

The industrial pH electrode adopts a ring-type polytetrafluoroethylene liquid junction, a solid electrolyte and a special glass sensitive membrane, which enhances the electrode reaction speed and anti-pollution ability

AE pH SENSOR SERIES



AE-ORP6041

▪ **Technical parameters**

Thread Connection: BNC

Material: Glass

Socket: S8

▪ **Application**

In various industrial processes including water treatment, pure water industry, power plants, etc.



AE-ORP6050

▪ **Technical parameters**

Zero potential point: 7 ± 0.5 pH

Conversion coefficient: > 96%

Pressure resistance: ≤ 0.6 MPa

Thread Connection: 3/4NPT

▪ **Application**

In various industrial processes including sewage and waste gas treatment and fields.

Installation of electrode

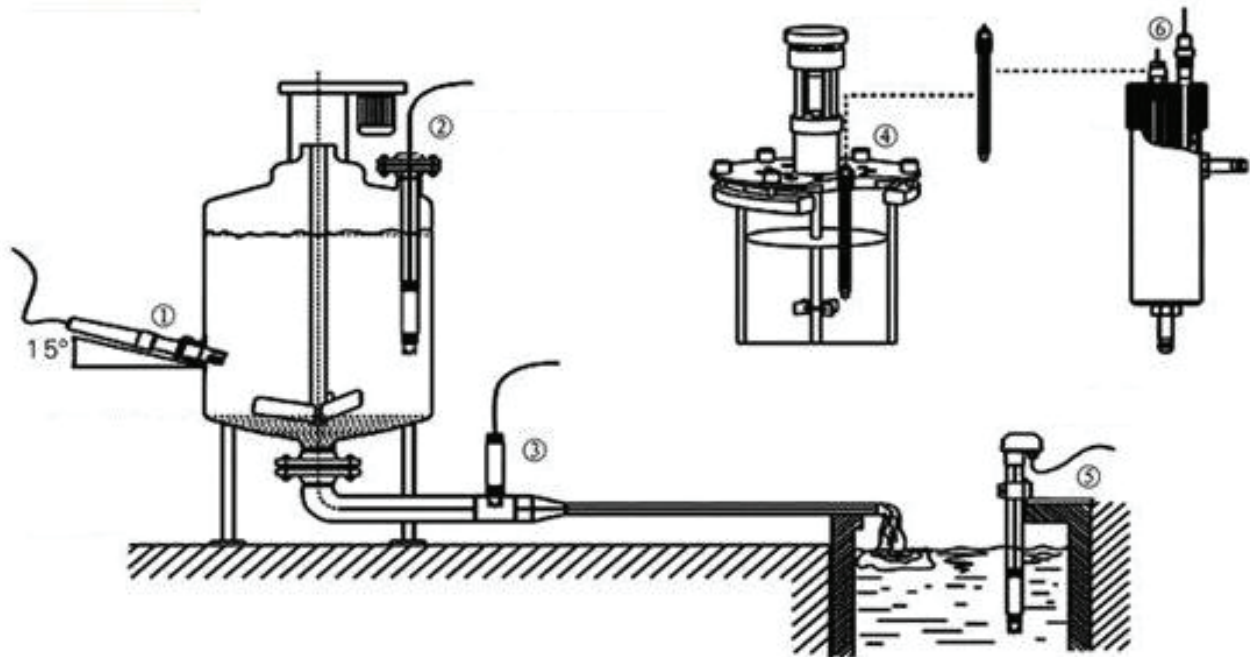

Schematic diagram of common installation method

- ① Side wall installation
- ② Flange mounted at the top
- ③ Pipe installation
- ④ Top installation
- ⑤ Submersible installation
- ⑥ Flow-through installation

The interface must be in 5 oblique angle, or it will affect the normal test and use of the electrode. We won't be responsible for any results due to this.

pH Calibration

A pH calibration is the procedure of adjusting the pH meter by measuring solutions of known pH values.

The characteristic of a pH electrode will change with time due to electrode coating and aging. And even a pH electrode would be stable over time, pH electrodes cannot be produced with identical characteristics.

In practice the response of a real pH sensor does not exactly follow the Nernst equation. This difference between the theoretical and actual behavior of a pH electrode must be compensated for. A calibration is required to match the pH meter to the current characteristics of the used pH sensor.

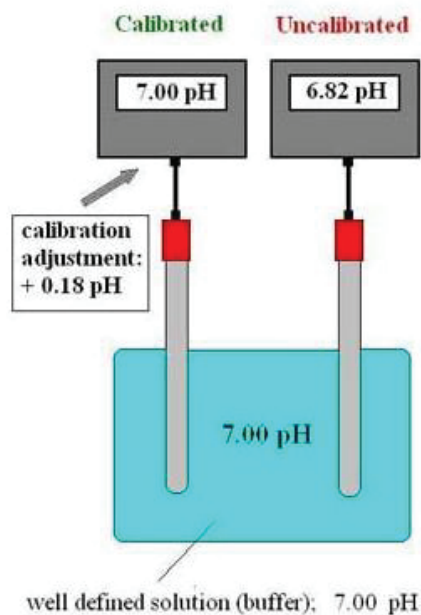

To achieve the best possible accuracy, the calibration should cover the range of the desired measurement values. If the readings go beyond the calibrated range, the pH meter assumes linearity and simply extrapolates the value to be displayed. The true value may be slightly different.

More advanced pH meters will let the user calibrate at three, four or five and even higher numbers of pH values. A multi-point calibration mean, in comparison to a two-point calibration, that you can calibrate your pH tester on both sides of the zero point (pH 7.00). This will expand your pH measurement range without the need of recalibrating.

Example) Three-point calibration at pH 4.00 , 7.0 and 9.21.

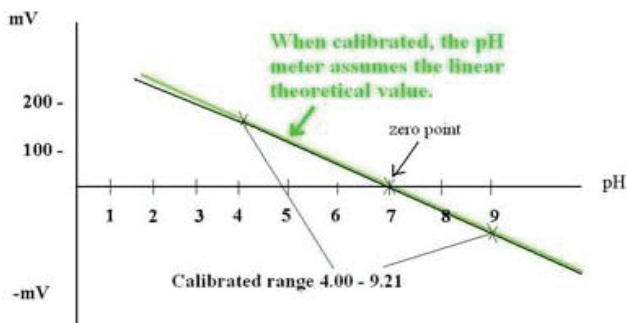

AE pH SENSOR SERIES

Electrode slope: The slope of the glass electrode is 59.16 mV at 25 °C theoretically, i.e. potential change of 59.16 mV for each pH change in the solution. But in fact, neither glass electrode can reach the theoretical value 100%; in general, the electrode slope is more than 98% of the theoretical value (percentage slope). In addition, the mV difference corresponding to each unit pH value varies under different temperatures. The conversion of temperature to electric potential difference is as follows:

$$\Delta E = 59.16 * [(273 + T) / 298] * \Delta pH$$

Corresponding relationship between pH and millivolt at 25°C

Potentiometer(mV)	pH	Potentiometer(mV)	pH
414.12	0.00	-414.12	14.00
354.96	1.00	-354.96	13.00
295.80	2.00	-295.80	12.00
236.64	3.00	-236.64	11.00
177.48	4.00	-177.48	10.00
118.32	5.00	-118.32	9.00
59.16	6.00	-59.16	8.00
0.00	7.00	0.00	7.00

Related Product



PTFE pH sheath



Stainless steel pH sheath



Flow cup



Electronic controlled box



AE ANDERSON
EUROTECH
VALVES AND INSTRUMENTS

For Your Sales and After Sales, please contact:

Indonesia Sole Distributor

PT. Multi Sukses Pratama

Jl. Bandengan Utara No. 80
Rukan Bandengan Indah D No.20

Jakarta Utara, Indonesia

☎ (62) (21) 29379590, 29379591, 68292838, 8822918 (62)

☎ (21) 29379571

E-mail: sales@suksespratama.com